

LT12-3 [12V10Ah]

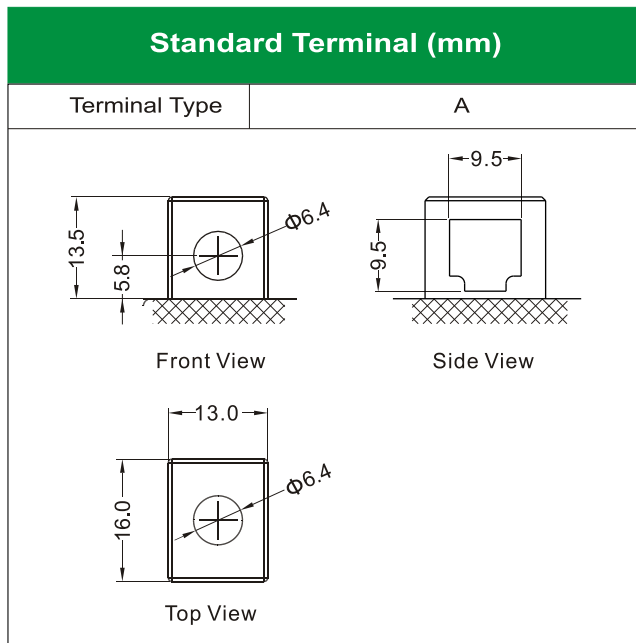
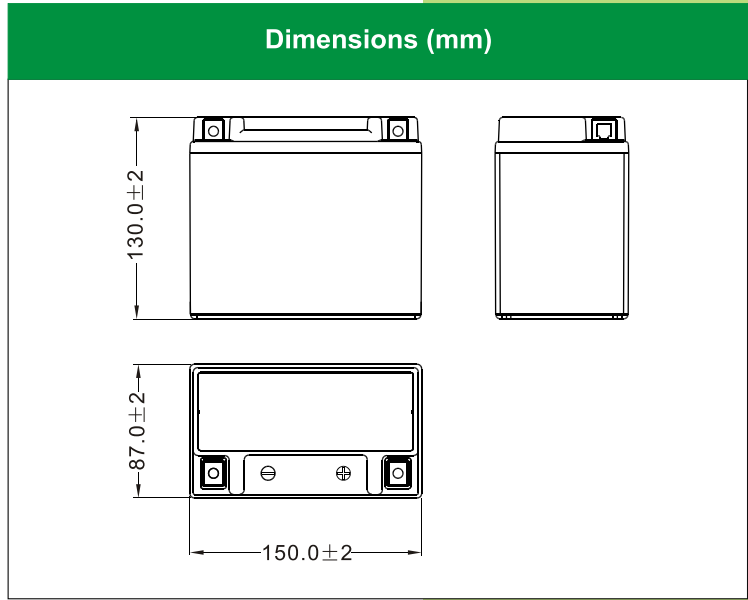

Physical Specification

| | | |
|-------------------------|---|-------------------------|
| Nominal Voltage | 12V | |
| Nominal Capacity (10HR) | 10AH | |
| Dimension | Length | 150 ± 2mm (5.91 inches) |
| | Width | 87 ± 2mm (3.43 inches) |
| | Container Height | 130 ± 2mm (5.12 inches) |
| | Total Height (with Terminal) | 130 ± 2mm (5.12 inches) |
| Weight | Battery(with acid): Approx 3.95kg (8.70lbs) | |
| | Electrolyte: Approx 0.79kg (1.74lbs) | |

- * Sealed and non-spillable AGM battery
- * Maintenance-free
- * Powerful 180 cold cranking amps
- * Shipped pre-charged and ready to install
- * Replaces LTX12L-BS battery

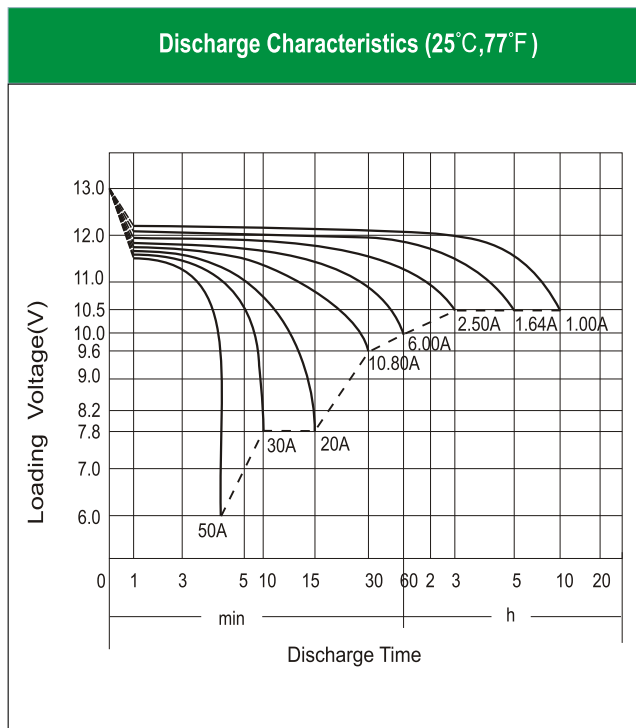

Electrical Specification

| | | |
|----------------------------------|--|---|
| Rated Capacity | 10 hour rate (1.00 A) | 10.00AH |
| | 5 hour rate (1.64 A) | 8.20AH |
| | 2 hour rate (3.50 A) | 7.00AH |
| | 1 hour rate (6.00 A) | 6.00AH |
| | 0.5 hour rate (10.80 A) | 5.40AH |
| Capacity affected by Temperature | 40 °C (104 °F) | 106% |
| | 25 °C (77 °F) | 100% |
| | 0 °C (32 °F) | 86% |
| | -15 °C (5 °F) | 65% |
| Self Discharge | Approximately 3% per month (25°C (77°F)) | |
| Charging Methods | Full Charge | Constant-Voltage Charge: Initial charging current: less than 3.0A Voltage: 14.40 V ~ 15.00 V at 25 °C (77 °F) Charging time: 15 ~18h Constant-Current Charge: Charging current: 0.1C ₁₀ =1.00A, when charging voltage up to 14.40V, continue to charge 4h |
| | Floating Charge | No limit on Initial charging current Voltage: 13.50 V ~ 13.80 V at 25 °C (77 °F) |