

# EBZ6L-BS [12V5Ah]

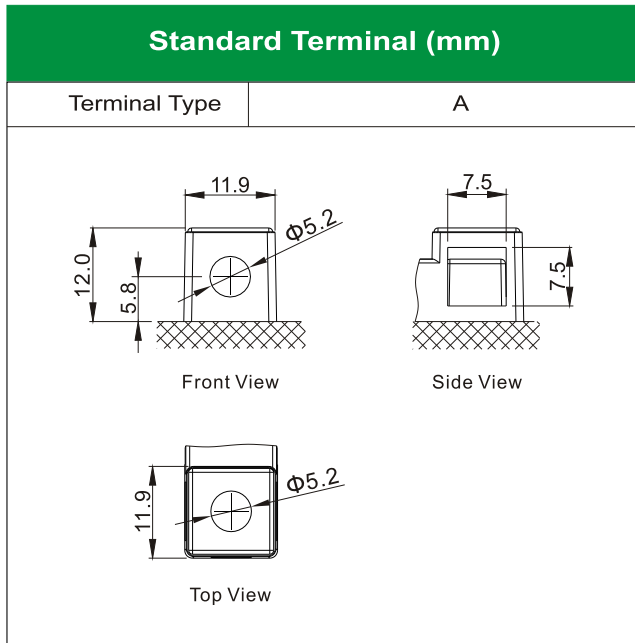
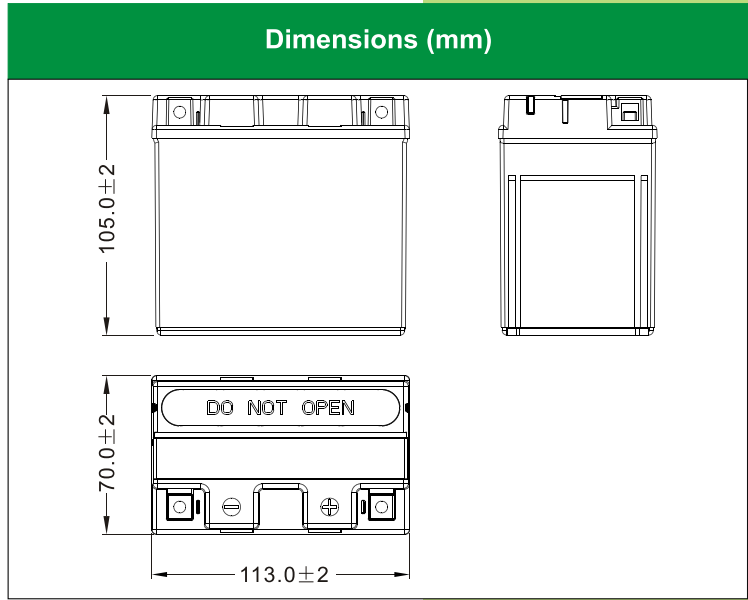

### Physical Specification

Nominal Voltage	12V	
Nominal Capacity (10HR)	5AH	
Dimension	Length	113±2mm (4.45 inches)
	Width	70±2mm (2.76 inches)
	Container Height	105±2mm (4.13 inches)
	Total Height (with Terminal)	105±2mm (4.13 inches)
Weight	Battery(with acid): Approx 1.97kg (4.34lbs)	
	Electrolyte: Approx 0.31kg (0.68lbs)	

- \* Sealed and non-spillable AGM battery
- \* Maintenance-free
- \* Powerful 90 cold cranking amps
- \* Shipped pre-charged and ready to install
- \* Replaces / upgrade for EBZ6-3

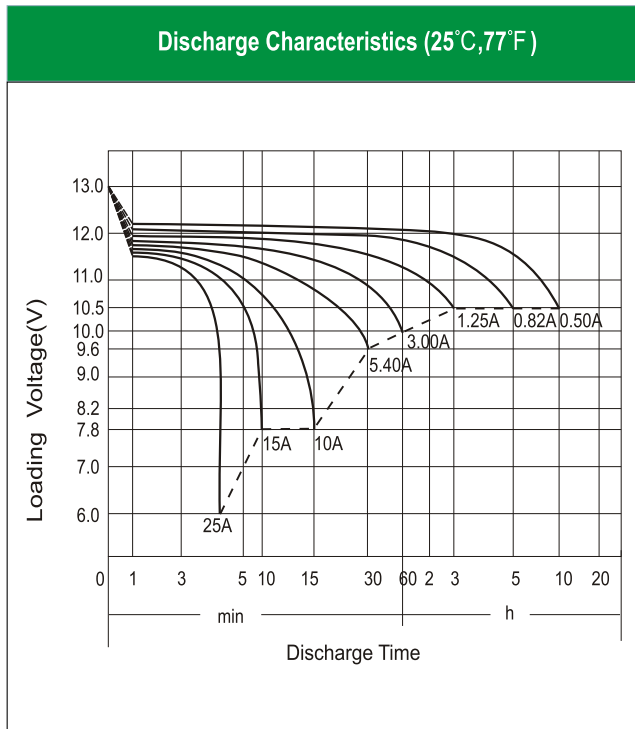

### Electrical Specification

Rated Capacity	10 hour rate (0.50 A)	5.00AH
	5 hour rate (0.82 A)	4.10AH
	2 hour rate (1.75 A)	3.50AH
	1 hour rate (3.00 A)	3.00AH
	0.5 hour rate (5.40 A)	2.70AH
Capacity affected by Temperature	40 °C (104 °F)	106%
	25 °C (77 °F)	100%
	0 °C (32 °F)	86%
	-15 °C (5 °F)	65%
Self Discharge	Approximately 3% per month (25°C (77°F))	
Charging Methods	Full Charge	Constant-Voltage Charge: Initial charging current: less than 1.5A Voltage: 14.40 V ~ 15.00 V at 25 °C (77 °F) Charging time: 15 ~18h Constant-Current Charge: Charging current: 0.1C <sub>10</sub> =0.50A, when charging voltage up to 14.40V, continue to charge 4h
	Floating Charge	No limit on Initial charging current Voltage: 13.50 V ~ 13.80 V at 25 °C (77 °F)