

EBZ12-BS (12V11Ah)

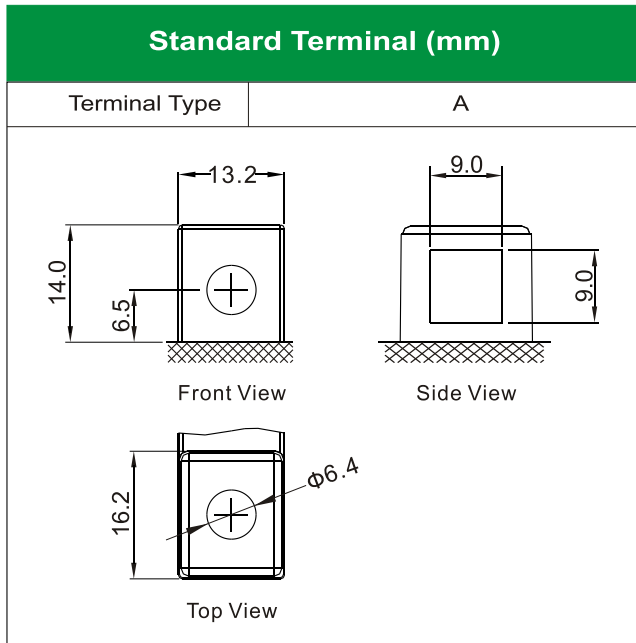
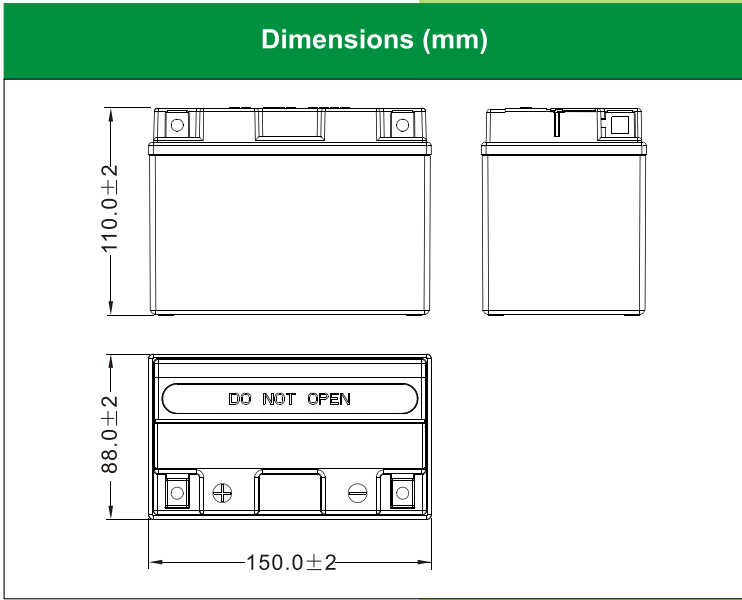

Physical Specification

Nominal Voltage	12V	
Nominal Capacity (10HR)	11AH	
Dimension	Length	150 ± 2mm (5.91 inches)
	Width	88 ± 2mm (3.46 inches)
	Container Height	110 ± 2mm (4.33 inches)
	Total Height (with Terminal)	110 ± 2mm (4.33 inches)
Weight	Battery(with acid):	Approx 3.91kg (8.60lbs)
	Electrolyte:	Approx 0.63kg (1.38lbs)

- * Sealed and non-spillable AGM battery
- * Maintenance-free
- * Powerful 210 cold cranking amps
- * Shipped pre-charged and ready to install
- * Replaces / upgrade for EBZ12A-4

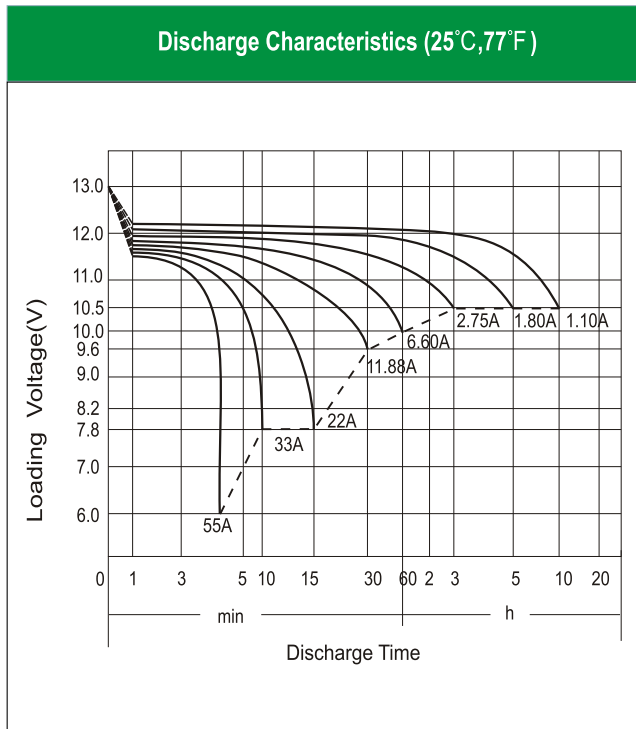

Electrical Specification

Rated Capacity	10 hour rate (1.10 A)	11.00AH
	5 hour rate (1.80 A)	9.02AH
	2 hour rate (3.85 A)	7.70AH
	1 hour rate (6.60 A)	6.60AH
	0.5 hour rate (11.88 A)	5.94AH
Capacity affected by Temperature	40 °C (104 °F)	106%
	25 °C (77 °F)	100%
	0 °C (32 °F)	86%
	-15 °C (5 °F)	65%
Self Discharge	Approximately 3% per month (25°C (77°F))	
Charging Methods	Full Charge	Constant-Voltage Charge: Initial charging current: less than 3.3A Voltage: 14.40 V ~ 15.00 V at 25 °C (77 °F) Charging time: 15 ~18h Constant-Current Charge: Charging current: 0.1C ₁₀ =1.10A, when charging voltage up to 14.40V, continue to charge 4h
	Floating Charge	No limit on Initial charging current Voltage: 13.50 V ~ 13.80 V at 25 °C (77 °F)