

Physical Specification (mm)

Nominal Voltage		12V
Nominal Capacity(20HR)		55Ah
Dimension	Length	275±2mm(10.83inches)
	Width	177.5±2mm(6.99inches)
	Container Height	175±2mm(6.89inches)
	Total Height(with Terminal)	202±2mm(7.95inches)
Weight With Acid		Approx 19.5Kg(43.0lbs)
Acid		1.310±0.015g/cm ³ (25°C)
Standard Terminal		DT
Cell layout		6
Case		Black-Material (PP)
Cover		Black-Material (PP)
Handle		Black-Material (PP)

Electrical Specification

Rated Capacity	20 hour rate(2.75A)	55Ah
Reserve Capacity (25A@10.5V)		120min
Cold Cranking Performance Amps(CCA) @0°F(-18°C)		650A(BCI)

Standard Terminal (mm)

Terminal Type	D	
	Positive	Negative
DT	19.5 ⁰ _{-0.3}	17.9 ⁰ _{-0.3}

Discharge Characteristics

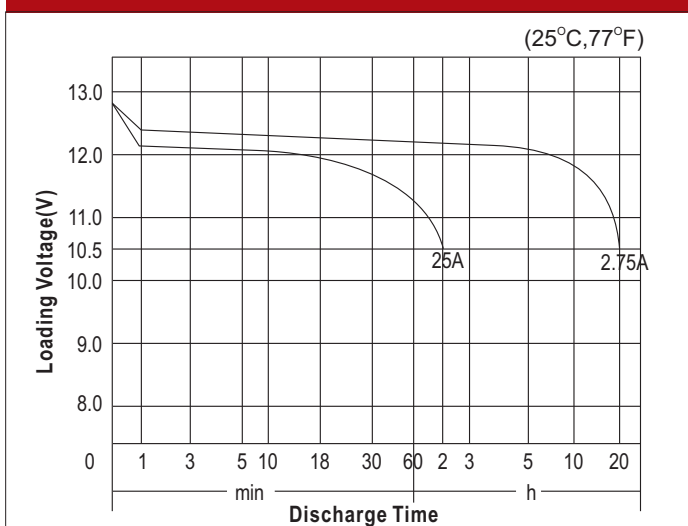

Dimensions (mm)

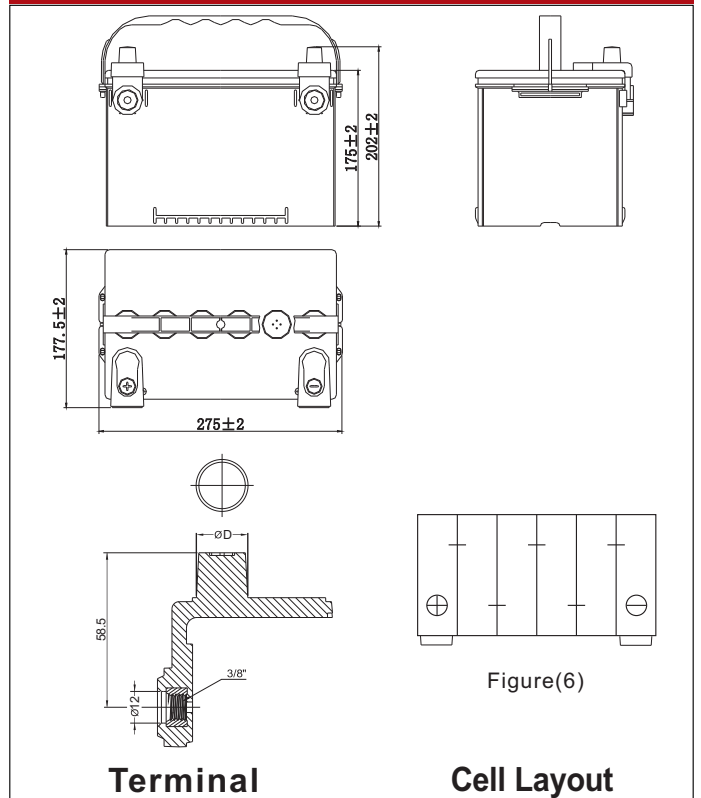

Discharge Characteristics

